

Construction Manual

AGRETO Drive-Over-Scale AW044

June 1, 2022



Content

1	Introduction.....	3
2	Scope of delivery	3
2.1	Scale	3
2.2	Mounting kit.....	3
2.3	Mounting frame (instead of mounting kit)	3
3	Intended Use	4
4	Safety	5
4.1	Safety instructions for the buyer	5
4.2	Safety instructions for the operator and assembly staff.....	5
5	Technical data	7
5.1	Weighing platform.....	7
5.2	Loadcells.....	7
5.3	Weighing electronics box.....	7
6	The principle of vehicle weighing with axle load scale.....	8
7	Operating requirements	8
7.1	Approach and exit.....	8
7.2	The ground/drainage	13
7.3	Vehicle characteristics necessary for a correct weighing	13
8	Building the foundation	15
8.1	Building instructions.....	15
8.2	The foundation plan	18
8.3	The reinforcement plan	18
8.4	Parts list for reinforcement.....	18
8.5	Building a foundation with a mounting frame.....	19
8.6	Preparation for laying the weighing signal cable	19
9	Mounting the scale	20
9.1	Overview of wiring, operation with PC.....	20
9.2	Overview of wiring, operation with weighing terminal	20
9.3	Placing the weighing signal cable	21
9.4	Lift in the Weighing Platform	22
9.5	Connection the signal cable	22
9.6	Weighing electronics box connection diagram	23
10	Installing the optional devices.....	26
10.1	Installation of the external display.....	26
10.2	Installation of 1 or 2 video cameras.....	28
10.3	Installation of the radio remote control	28
11	Disposal	28
12	Warranty / guarantee AGRETO drive-over-scale.....	29
13	Warranty / guarantee accessories	29
14	Imprint.....	30

1 Introduction

Thank you that you have chosen an AGRETO drive over scale. You have purchased a robust scale for everyday practice.

Please read this manual carefully before you begin the installation of the scale and take the scale in operation.

2 Scope of delivery

Please check with the delivery, whether you have received all parts of the Agreto drive over scales. Check also the components for shipping damage. Store all components prior to installation in a weather-protected place.

2.1 Scale

- 1 weighing platform 3,4 x 1 m
- 4 loadcells with foot
- 2 screws with ring for transporting
- 1 Weighing electronics box
- 10 m cable with plugs (or your desired length)
- 1 Construction manual

2.2 Mounting kit

- 4 edge protection frame parts with welded concrete claws
- 4 Weighing foot support plates
- 12 anchor bolts with fastening material

2.3 Mounting frame (instead of mounting kit)

- 1 C-profile frame with integrated support plates

For using the scale at least one of the following parts is necessary:

AW07 Software-kit for AGRETO Drive-over-scale or

AW08 AGRETO Weighing Terminal for axlescales

3 Intended Use

The AGRETO drive over scale is used for weighing various vehicles and trailer combinations with any number of axes in the commercial, as well as in the agricultural sector with high accuracy. It also determines axle weights and total weights of vehicles with large low-pressure tires and multiple axles as tandem and tridem with various axle distance.

The weighing is done dynamically in the normal case, ie. during the crossing at walking speed. In weighing of liquids or semi-full tanks, we recommend static weighings, ie. each axis at a standstill on the platform.

Axle scales are not admitted to official calibration for the determination of vehicle weights and therefore cannot be used as trade scales or to replace a calibrated weighbridge. Axle scales are ideal for check weighing in the agricultural sector and can be used quickly, cheaply and easily.

The AGRETO Drive-over-scale is ideal for check weighing and automatic documentation of transport quantities.

It is essential to observe the conditions of use detailed in this manual. Above all, the proper condition of the roadway before and after the scale is mainly responsible for achieving good weighing results.

4 Safety

4.1 Safety instructions for the buyer



Important!

Make sure that every person who works for the first time with the AGRETO drive over scales, has read and understood this manual.

4.2 Safety instructions for the operator and assembly staff



Two liftin rings on the product are available for transport with lifting device. When transporting with pallet forks to lift the platform is centered, and to observe the width. When transporting with lifting equipment suitable means shall be used.



Persons handling with the platform have to wear safety shoes.



Persons handling with the platform have to wear safety gloves.



During transport the entire palette can slip on the vehicle. Transport and loading personnel should be instructed to pay attention to load securing.



Please pay attention that during installation there is the risk of crushing between platform and foundation.



The scale must not be stored and used in an explosive environment.



Pay attention to the danger of stumbling in the area of the platform.

Pay attention to the danger of stumbling in the range of potentially unnecessary objects / tools and the risk of falls in the area of the foundation.



Pay attention to the risk of slipping in the region of the platform.



Keep away from the drive over scale during lightning storms.



Note the risk of falls in the region of the foundation.
Secure the danger zone by suitable means.

5 Technical data

5.1 Weighing platform

- Galvanized steel construction, designed for loads of up to 15t
- Dimensions: 3400 x 1000 x 280 mm (width x length x height in direction of travel)
- Weight: 650 kg

5.2 Loadcells

- 4 high-resolution shear beam cells with 10.000 kg, 2 mV/V, 350 Ohm
- Total nominal load for all weigh cells: 40.000 kg, overload 150 %, brakeload 300 %
- Protection class IP68 (dustproof and waterproof)
- Operating temperatur: -35 to +65 °C, temperature compensated: -10 to +40 °C

5.3 Weighing electronics box

- Waterproof electronics box under the maintenance cover in the weighing platform
- Integrated heating element (about 2 W)
- 4-way A / D converter for separate evaluation of each load cell
- Diagnostic functions for component monitoring
- Connection terminals for 4 load cells
- RS485 interface for data transfer to the PC or weighing terminal
- Screw plug for connecting the connection cable
- Protection class IP68
- Dimensions: 225 x 185 x 60 mm (LxWxH)

6 The principle of vehicle weighing with axle load scale

An axle scale weighs one axle after the other and calculates the total sum of these axle loads. This result tells us the total weight of a vehicle, as long as loads do not move from one axle to another while driving over the scale. This weighing principle is suitable for all vehicles, provided the platform size is sufficiently large in relation to the tyre contact area. Individual axles can be weighed either statically (stationary) or dynamically (during the crossing).

In order for the sum of the masses represents the weight of the vehicle, it is important that the vehicle can roll without any acceleration or deceleration in horizontal position absolutely neutral over the weighing platform. Each level difference and every bump before and after the weighing platform can cause shifting weight from one axle to the other.

For properly installed axle load scales, the maximum deviation between total axle loads and vehicle weight, depending on the type of vehicle is 0 to + / - 1%. During dynamic weighing, it is important that the vehicle does build up neither oscillations during the crossing nor braking or accelerating. If the vehicle rolls over the weighing platform neutral, the deviations are not greater than for a static weighing.

Axle scales are not admitted to official calibration for the determination of vehicle weights and therefore cannot be used as trade scales or to replace a calibrated weighbridge. Axle scales are ideal for check weighing in the agricultural sector and can be used quickly, cheaply and easily.

The Agreto-drive-over scale is an advancement of the axle scale. It has control and security mechanisms to optimize the use in agriculture. The platform is extremely robust and weighs axle loads up to 15,000 kg. The load cells and the electronics of the weighing platform correspond to the protection class IP 68. The control software detects tandem / Tridemachsaggregate, direction, speed and controls the quality of weighing procedures and documents all operations on the scale.

7 Operating requirements

7.1 Approach and exit

The approach and exit are the most important components of a drive-over-scale that greatly influence the accuracy of weighing results. An improperly constructed roadway can't be compensated by other factors, regardless of whether a dynamic or static weighing is performed.

This problem doesn't occur with vehicles that have only one or two axles, as almost no load is shifted from one axle to the other when driven slowly, even if the roadway is slightly bumpy. But it wouldn't make sense to limit a scale to just this type of vehicle.

As soon as multiple axle vehicles (tandem trailer, 3-axle tractors, 3-axle trailer, semi-trailer with tandem or tridem axles) are used, the roadway has to be constructed with much more care. In multiple axle vehicles the axles influence one another, regardless of the distance between them. For semi-trailers even a change in level for the tractor's front axle can change the weight of the trailer's rear axle.

If possible, the approach and exit surfaces before and after the platform should be constructed in such a way that the entire trailer that has to be weighed is on a flat, level surface before and after the weighing platform, while it rolls in a neutral way, without steering, accelerating or slowing down, over

the weighing platform. Differences in level of any kind (steep inclines, slopes, elevations, depressions, debris and other unevenness) during the approach or exit should be avoided at all costs.

This means that for a total vehicle length of 15 m (semi-trailer, distance from first to last axle) a fully level and even roadway of 31 m is required (15 m for the approach, 1 m for the scale, 15 m for the exit).

If this isn't possible, the following compromises can be made that will make the construction of roadway and foundation more labour-intensive:

Lateral slope for drainage, weighing platform inclined sideways:

If the scale is built into an already existing situation, and the roadway has a uniform lateral slope for drainage (usually 0.5% to 2%), it's possible to build the scale with an equal slope to guarantee a constant crossing. The entire foundation has to be constructed with this same lateral slope. The scale might have to be calibrated once in operation.

Uniformly rising or sloping roadway

If it isn't possible to create a level roadway in the required length, it can be constructed with an evenly rising incline or sloping decline. The slope has to allow the vehicle to cross the roadway without having to brake or accelerate.

The scale has to have the same slope as the rest of the roadway. This means that the entire foundation has to be constructed with an incline or decline in the driving direction. The scale might have to be calibrated once in operation.

Whatever way the scale is built, it's extremely important that the approach, scale and exit have the exact same and constant slope (either level or slanted). Any change in the incline or decline will lead to measurement errors with multiple axle vehicles.

Best suited for approach and exit are solid concrete roadways or precast concrete elements. On asphalted surfaces ruts can appear after a while that may lead to differences in level with the weighing platform. These ruts have to be filled with appropriate materials. Paved and graveled roadways will eventually lead to fluctuations in weighing results. Especially with multiple axle vehicles these fluctuations due to an improperly constructed roadway can deviate from true axle weights by several percent.

AGRETO Drive-Over-Scale

Below are examples of how an improper lane impact the axle load of a vehicle with a tandem axles. The illustrations are greatly exaggerated for better understanding, the vehicles are shown without suspension.

At a proper road surface, there is no weight changes of the axes.

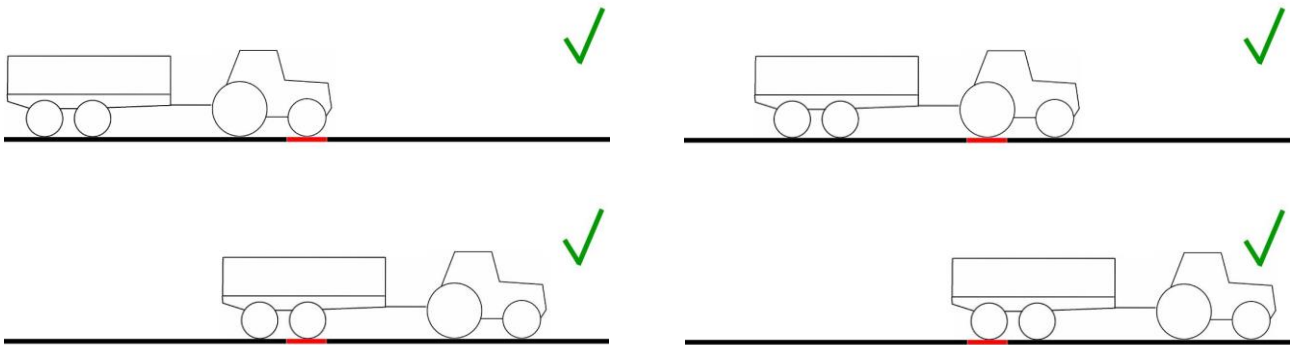

If the platform is installed too low there can be load changes. In worst case the trailer will not be weighed at all.

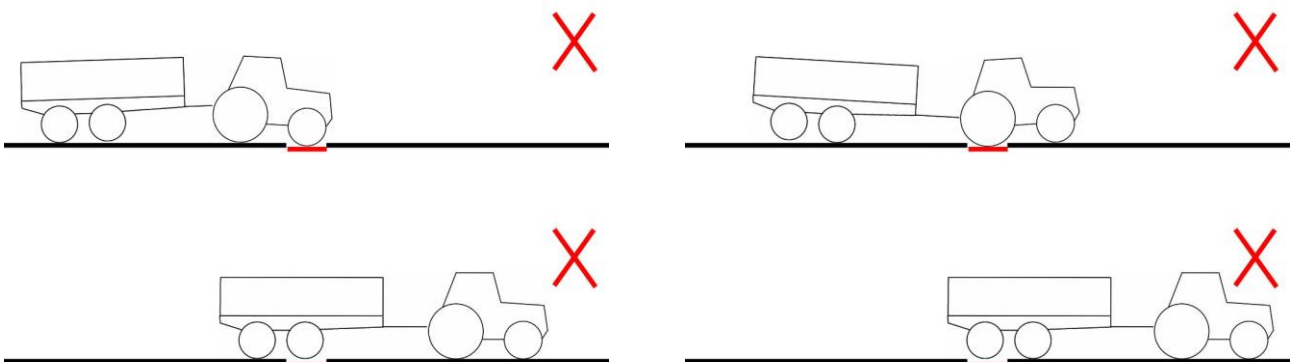

AGRETO Drive-Over-Scale

If the platform is too high, it can lead already on the tractor to load changes, the trailer is weighed twice in the worst case.

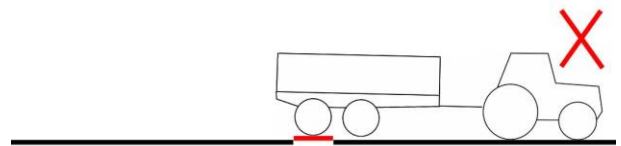
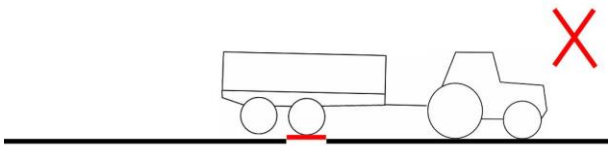
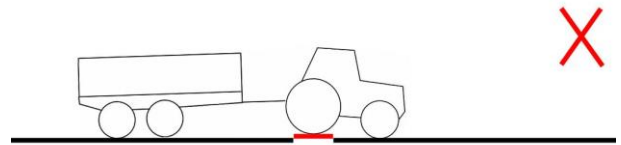
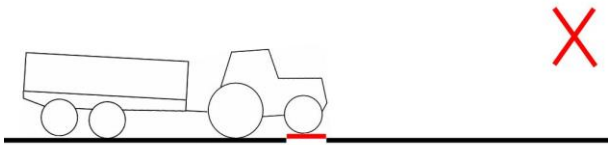

Bumps in the road always cause vibrations and movements in the vehicle. Depending on the location and extent of the irregularities it comes to various deviations.

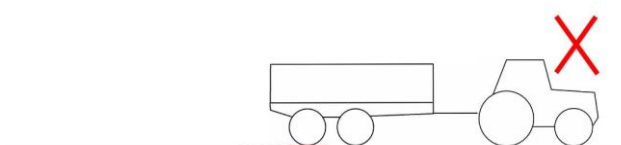
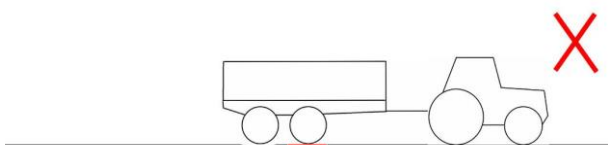
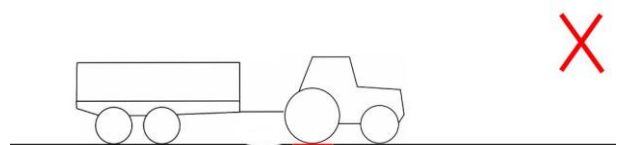
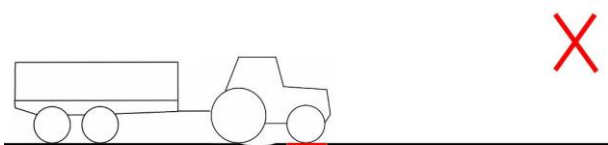
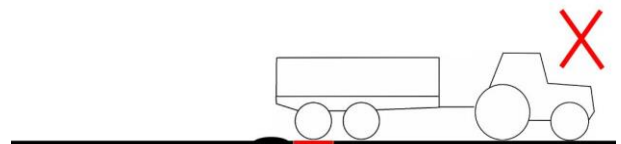
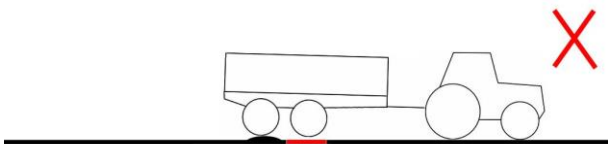
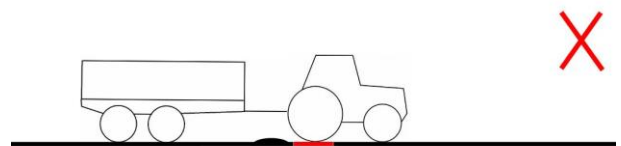
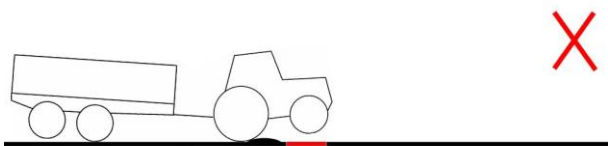

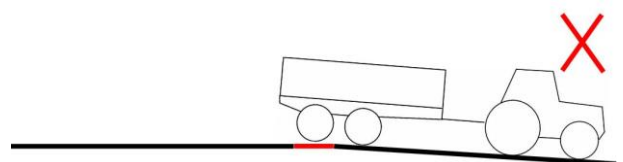
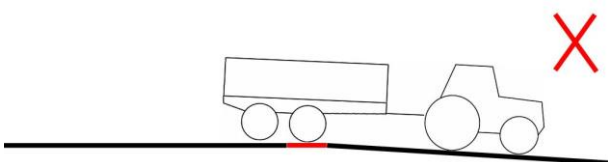
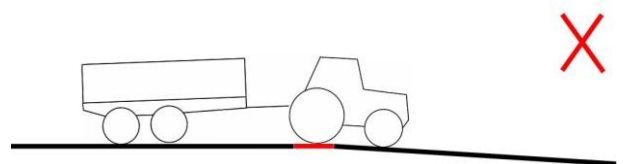
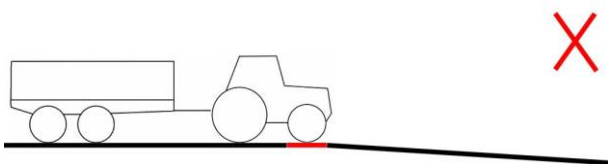
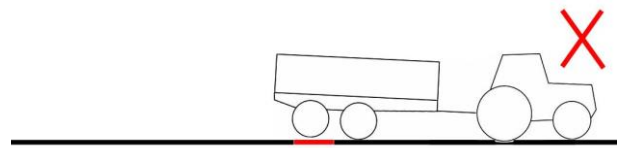
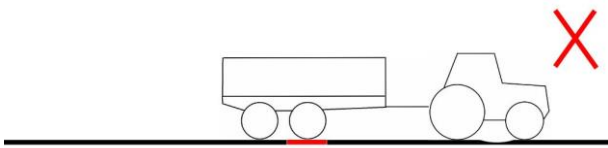
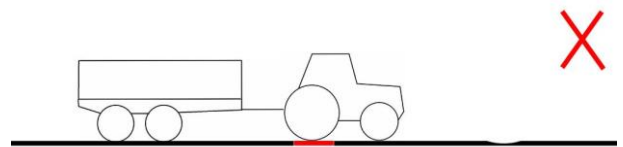
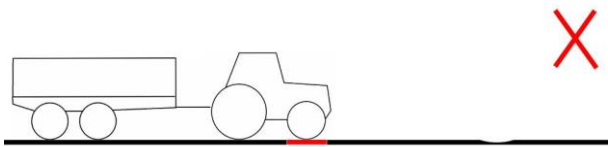
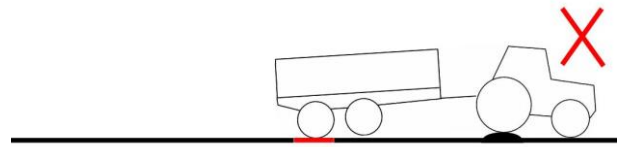
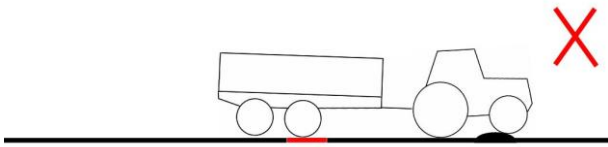
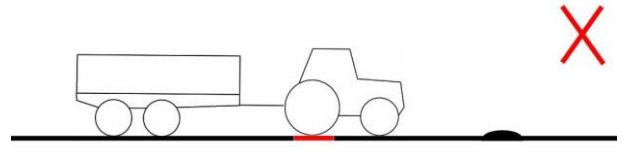
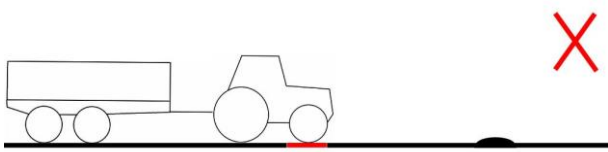

7.2 The ground/drainage

The foundation surface must be sustainable and free from water logging. The foundation must extend down to frost-proof depth. In the foundation a drainage must be installed to safely divert also large quantities of rain storm water. The scale may never be under water.

7.3 Vehicle characteristics necessary for a correct weighing

The Agreto drive over scale can weigh all vehicles which are approved for the traffic. However, there are criteria that need to be fulfilled.

7.3.1 Driving speed

The vehicle must be for the dynamic weighing in a position to travel smoothly in the range of about 2 to 6 km / h.

7.3.2 Wheel contact surface

With dynamic weighing wheels can be weighed with a maximum wheel contact surface of 80 to 90 cm. The greater the wheel contact surface, the lower the speed has to be in order to obtain a proper weighing result.

For static weighing wheels can be weighed with up to 100 cm footprint - provided they are during the weighing entirely on the weighing platform.

The outside width should not exceed 3,2 m, otherwise the tires could be partially outside the platform.

7.3.3 Axle distance

By the standard equipment of the Agreto drive over scale with a axle detection system, there is no restriction at axle distances and spaces between the wheel footprints.

7.3.4 Track

The static of the axle load scale was calculated so that a vehicle with 15 t axle load can centrally drive over the weighing platform. When a vehicle with 15 t axle load drive over the weighing platform, one rolling wheel of axle in the middle over the weighing platform and the other wheel of the axle rolling over the foundation beside the platform, the steel structure is already charged to the load limit. Therefore, please avoid such unbalanced loads.

7.3.5 Situations that can damage your axle load scale

Avoid turning and maneuvering on the weighing platform. This is especially true for vehicles with tandem or tridem axes because these can exercise high lateral forces on the weighing platform.

Avoid high peak loads. Never drop a solid object on the weighing platform (even a 1 kg hammer dropped from a height of one meter, can produce peak loads of 4000 kg). Special caution is also advisable in vehicles without pneumatic tires and no suspension (e.g. forklifts). These vehicles can even if they are relatively light produce peak loads of more than 20 tons.

To avoid damage by snowplows in wintertime install a visible marking of the scale.

8 Building the foundation

In this chapter the construction of the foundation is described. If you use a pre-assembled mounting frame, you can go to chapter 8.5.

The foundation must be constructed with the greatest care. Mistakes that are made during the reinforcement or concreting phase can damage your axle load scale, even years later. Therefore exactly follow the instructions in this manual. If you have questions, do not hesitate to contact AGRETO directly. All the reinforced concrete work needs to be carried out by trained personnel. The foundation should cure for 24 days before it can be fully used. Ask a structural engineer whether our construction method is suitable for your subsoil.

8.1 Building instructions

To construct the necessary reinforced concrete shell, proceed as follows, using the foundation plan and reinforcement plan:

- Remove the humus layer or topsoil from the entire excavation area.
- Dig out the excavation pit up to a depth below the frost line (see foundation plan). Make sure no water gets into the excavation, or that it can easily be removed.
- Cover the excavation pit bottom with a 220 g/m² fleece, like Polyfelt® TS or equivalent. This fleece serves as a subbase layer for the frost layer or concrete filter. Make sure there's at least 40 cm of overlap.
- Install the drainage pipe (approx. 100 mm) and lay it in the middle of the pit all the way up to the upper edge of the foundation base. If it isn't possible to connect the drainage pipe to a sewer or let it drain in the open via a slope, make sure to use a perforated pipe or tube, so that the water can percolate into the gravel. Make sure that no rodents can get into the drainage.
- For the frost layer you would ideally use cement-bound drainage gravel with a 16/32 mm grain size. You can order it as a finished product or make it yourself as follows: fill the excavation pit with gravel (16/32 mm grain size) and cover the gravel evenly with a thick layer of cement slurry. This way the drainage gravel does not need to be compacted.
- For the floor slab of the reinforced concrete shell you need AQ 55 welded wire mesh panels (100 x 100 mm mesh size, 5.5 mm wire thickness, see reinforcement plan). These form the upper and lower reinforcement of the floor slab. To make sure it is covered by at least 2.5 cm of concrete you need spacers between the upper and lower wire mesh panels. Follow the reinforcement plan when laying the reinforcement.
- The steel cage for the reinforced concrete shell is braided with rebar. It is recommended to get the necessary bars and brackets from a specialized company. Additionally you will need binding wire, mounting rebar, spacers, etc. Follow the reinforcement plan when laying the steel core. The concrete cover should be at least 2.5 cm thick. Make sure that the steel brackets, as depicted in the reinforcement plan, connect the corners of the steel frame in both directions. It's also possible to connect the AQ 55 mesh panels for the upper and lower side of the floor slab with the reinforced concrete shell's steel cage.
- When the steel cage is finished, the formwork for the lateral surfaces can be put into place and secured. Follow the foundation plan.

- Pour the foundation's floor slab with a thickness of approx. 20 cm. Use ready-mixed concrete with the C25/30 F45 GK32 B7 specification, or the same concrete that is used for the platform: C30/37 F45 GK22 B7. The floor slab's concrete needs to be compacted through vibration. If air temperatures are high, a sheet should be used to prevent the concrete from drying too fast.
- After two days of curing the inner formwork for the foundation frame can be put up. Make sure there is enough support and bracing. The clear width of the foundation frame must follow the plan exactly. Check whether your formwork is at right angles through diagonal measurements.
- Bend the concrete anchors in a right angle away from the protective frame and attach them with nails or screws to the inner formwork. Make sure that the protective frame's mitre cuts exactly fit into the corners. If the mitre cuts do not fit, the inner formwork doesn't have the right dimensions. The protective frame has to be mounted exactly to what will be the roadway surface.
- Make sure to put the pipe in place for the signal cable to the PC. It has to be installed above the water drainage pipe. The foundation frame has to be 20.5 cm thick. Use ready-mixed concrete with the C25/30 F45 GK32 B7 specification, or the same concrete that is used for the platform: C30/37 F45 GK22 B7. After concreting the side walls, the concrete needs to be compacted through vibration. If air temperatures are high, a sheet should be used to prevent the concrete from drying too fast.
- After 7 days of curing the formwork can be removed. Position the 4 bearing plates for the weighing feet according to plan. Mount both bearing plates with the guide rings diagonal to each other, or on the same long side. **To be sure, measure the exact dimensions of your platform.** Measure for each side the centre distance to the feet and position the bearing plates accordingly.

ATTENTION: The support plates on the long side of the concrete tub are offset by 10 cm each inwards!

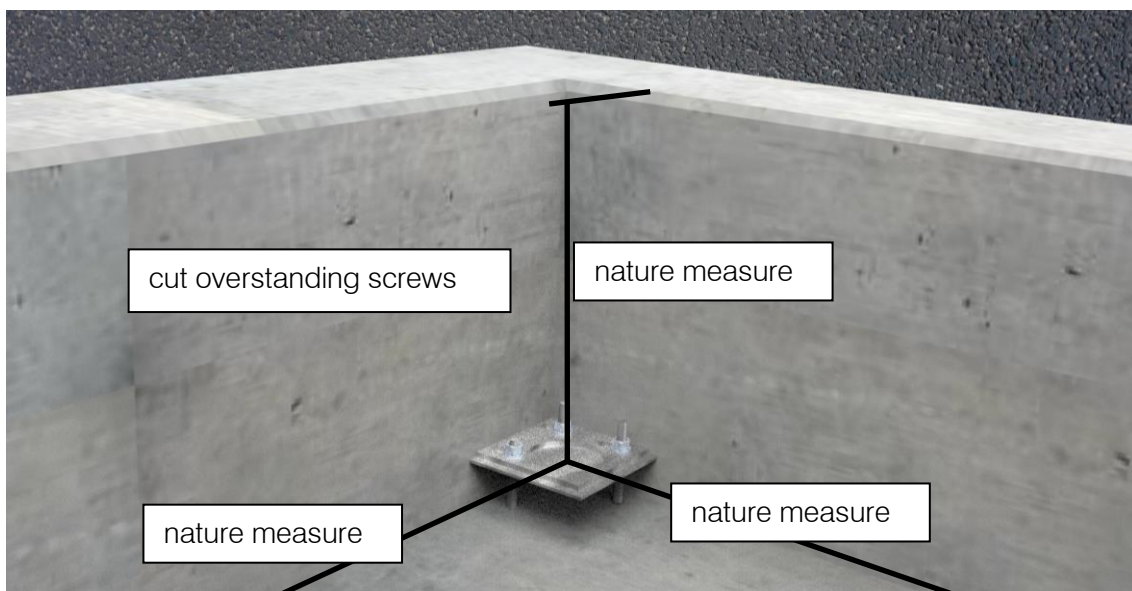

- Drill the holes for the anchor bolts (see detailed drawing). The anchor bolts are driven in and braced on the concrete surface with a washer and nut. The anchor bolts will only hold under tension. Align the bearing plates in the exact right distance to the protective frame (=roadway surface). Also be sure to measure the platform, including the legs. Tighten the mounting screws and then cut off the protruding parts of the anchor bolts, so that they don't come into contact with parts from the weighing platform.
- Pour concrete under the bearing plates without leaving voids (see image below). After that a lightly reinforced sloping screed has to be poured for the water drain. Make sure there's an even slope all the way to the drainage pipe.

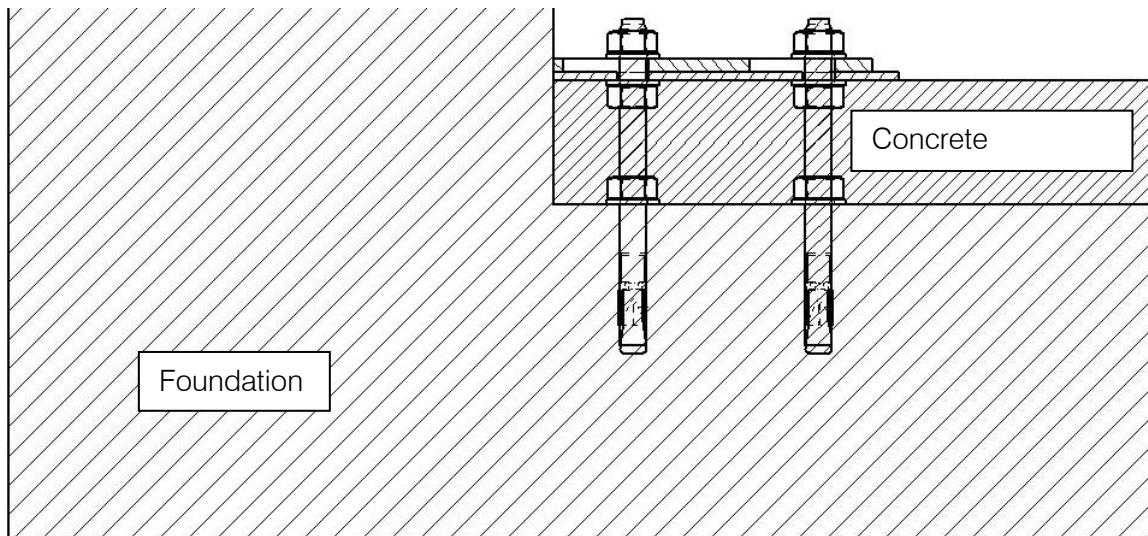

- After the formwork is removed, the working spaces need to be filled with gravel and compacted in layers. The approach and exit need to adjoin the reinforced concrete frame. Make sure there is no difference in level between approach, exit and weighing platform. The reinforced steel shell should cure 28 days before it can be fully used.
- It is strongly recommended to construct a concrete roadway at least 3 m before and behind the scale. You can also concrete the roadway and upper part of the foundation at the same time, to avoid joints and differences in level.

8.2 The foundation plan

See enclosed foundation plan

8.3 The reinforcement plan

See enclosed reinforcement plan

8.4 Parts list for reinforcement

item	description	qty	diameter [mm]	length [m]	Total length [m]
1	Main bars top and bottom	16	14	3,78	60,48
2	Main bars center	4	8	3,78	15,12
3	Clamp upright	40	8	1,40	56,00
4	Clamp to lie	16	8	0,95	15,20
5	Crossbars top and bottom	12	14	1,38	16,56
6	Crossbars center	4	8	1,38	5,52

2 pcs steel mesh AQ 55 for the bottom plate according reinforcement plan

enough spacers for the steel mesh

enough binding wire

8.5 Building a foundation with a mounting frame

Using the pre-assembled mounting frame means the concrete shell does not need to be constructed. But the frame has to be positioned accurately and concreted on a stable surface.

It is recommended to construct reinforced strip foundations in the area of the lateral bearing plates in the driving direction along the scale to avoid subsidence.



Make sure the substructure is 10 cm lower than the mounting frame, so that concrete can be poured under the frame and especially the bearing plates in the corners.

Position the mounting frame in such a way that the top of the frame and the roadway form one surface and make sure the frame doesn't shift or twist during the pouring and compacting of the concrete.

Press at least two struts on the inside of the frame, at the underside and the top, to prevent the frame from getting pushed in.

Make sure the space below the bearing plates is properly filled and create a slight slope towards the water drain.

In 2 corners of the mounting frame support plates are used, which prevent slipping of the platform. These support plates can be moved laterally by 20mm with each of the 3 slots in the mounting screws inward or outward..

Measure the natural dimension between the two foot rests (center - center) and the two measurements between the foot rests (center) and platform edge. It may be that the distances have changed slightly due to the concreting of the platform. Check that the two support plates are in the right place and tighten the 3 screws.

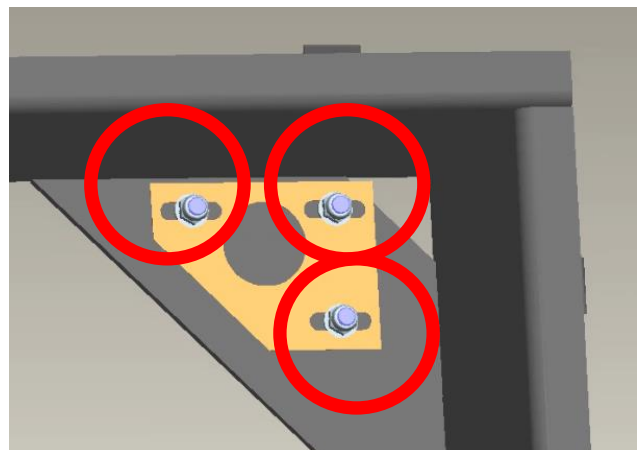

8.6 Preparation for laying the weighing signal cable

Consider a location for the PC or weighing terminal near the scale. The location should be indoors or at least moisture protected. Lay a waterproof installation tubing of at least 50 mm inside diameter from the scale foundation to the location of the weighing PC or weighing terminal.

9 Mounting the scale

The scale may only be installed when the concrete foundation has completely hardened.

9.1 Overview of wiring, operation with PC

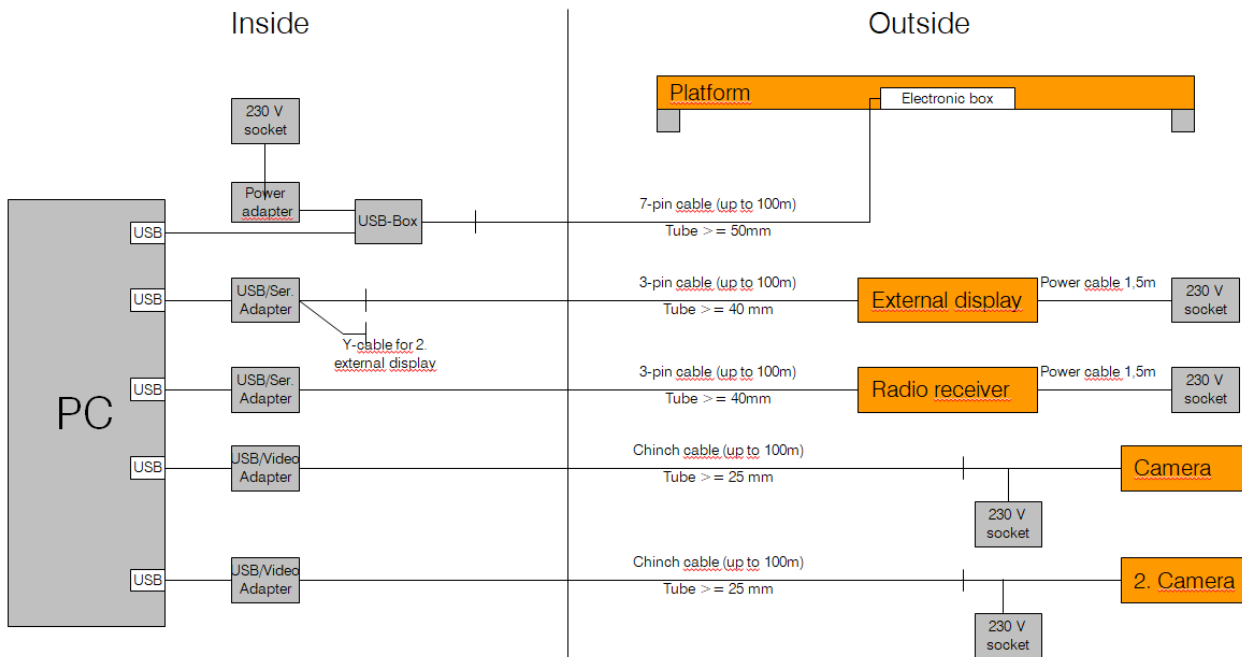

9.2 Overview of wiring, operation with weighing terminal

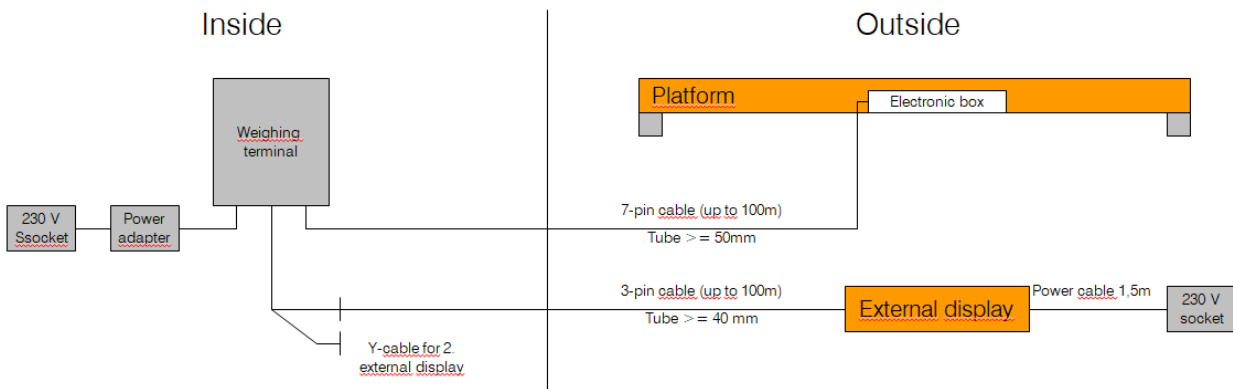

9.3 Placing the weighing signal cable

Pull the weighing signal cable through the tube from the scale to the pc or terminal. The cable is delivered with mounted plugs.

Pinning weighing signal cable 6-pin

Pin	Function	Cable color
1	Not used	
2	Data A	Green
3	Data B	Yellow
4	Data GND (not used with 5-pin cable)	Blue
5	Data 5+	Grey
6	Supply +	Brown
7	Supply -	White

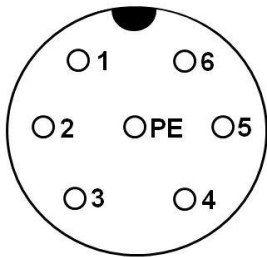

Top view (female)
Connection on the electronic box

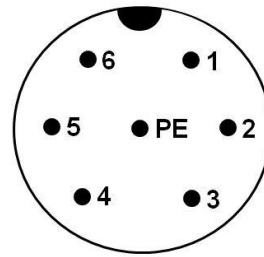

Top view plug (male)
Connection to the USB-Box
or terminal

9.4 Lift in the Weighing Platform

The weighing platform is about 700 kg and can be lifted with the front loader or similar:

- Place the platform-side connector of the weighing signal cable approximately in the middle of the foundation.
- Screw the two bolts with the ring into the provided threads in the platform.
- Attach suitable straps (ropes, chains) to the screwed bolts.
- Check the adhesive tapes securing the feet to the load cells and replace them if necessary.
- Position the scale as exactly as possible and parallel over the foundation.
- On each side (diagonal), a helper should place an approx. 1.5 m long angle iron with the lower end in the corner of the foundation, hold it at the upper end and use the angle iron to stabilize and guide the platform.
- Lower the platform slowly and let it slide gently into the foundation
- The weighing platform must be able to stand with a uniform, circumferential gap in the foundation without tilting and without a level difference between the platform and the edge protection frame.
- If the weighing platform is too low, you can compensate for this by placing suitable steel discs under it.
- If the weighing platform is too high, the foot rests must be turned off.

9.5 Connection the signal cable

Open the maintenance cover in the center of the weighing platform and connect the signal cable to the appropriate screw connector on the electronic box.

Inside connect the cable to your PC or the weighing terminal.

9.6 Weighing electronics box connection diagram

If you need to add or swap components, make sure you follow the connection diagram:

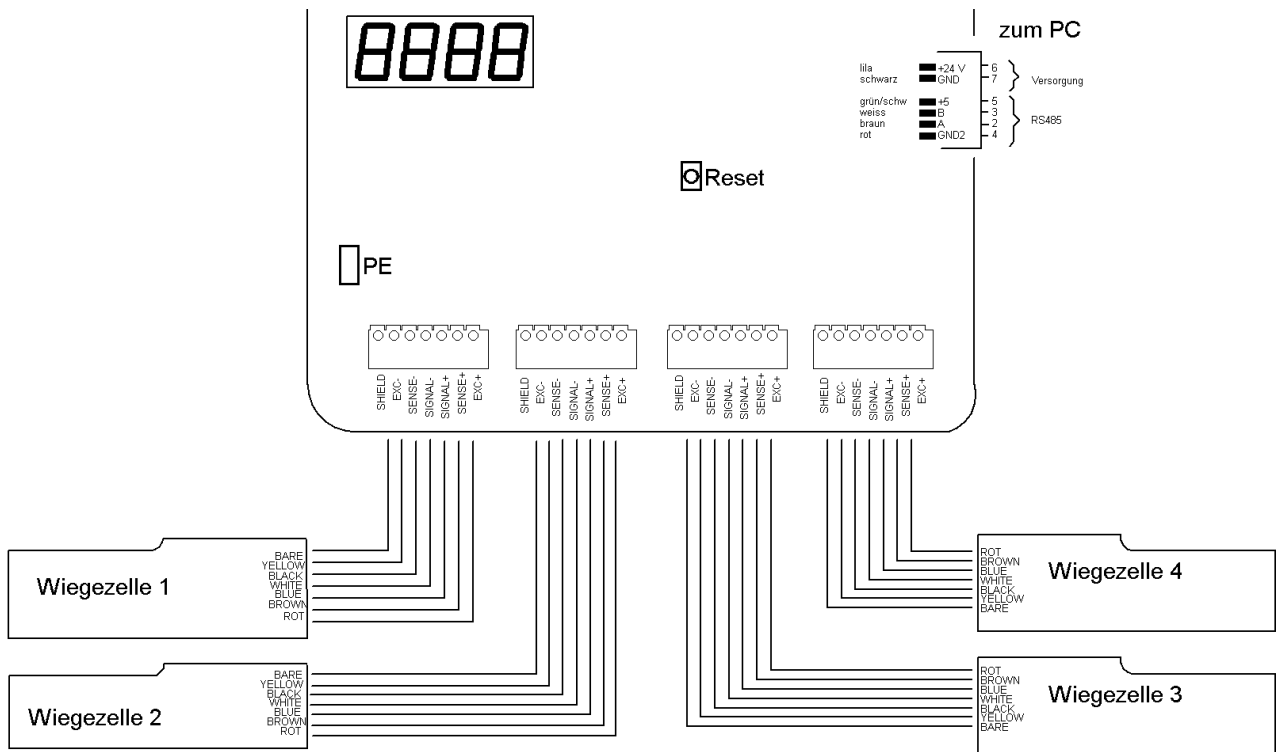

View of the weighing platform from above, positions of load cells.

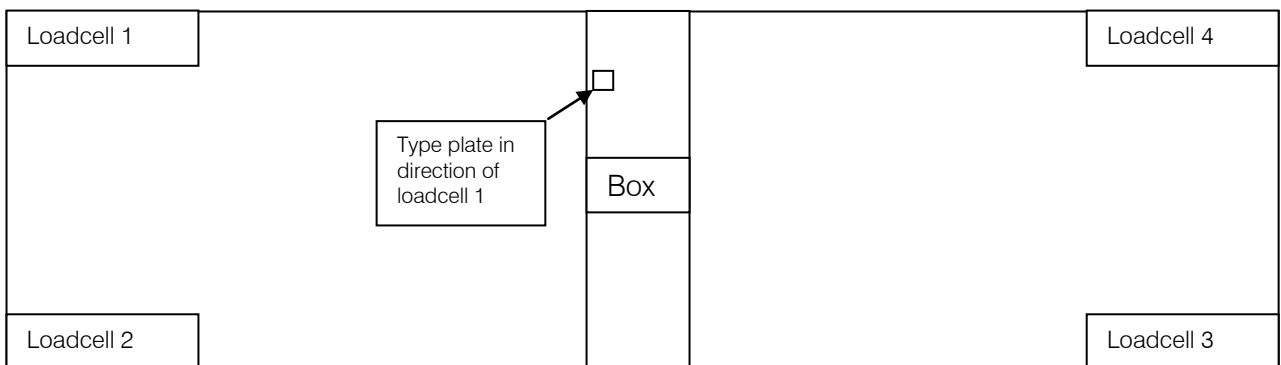

9.6.1 Connecting the loadcells

View of the electronic box

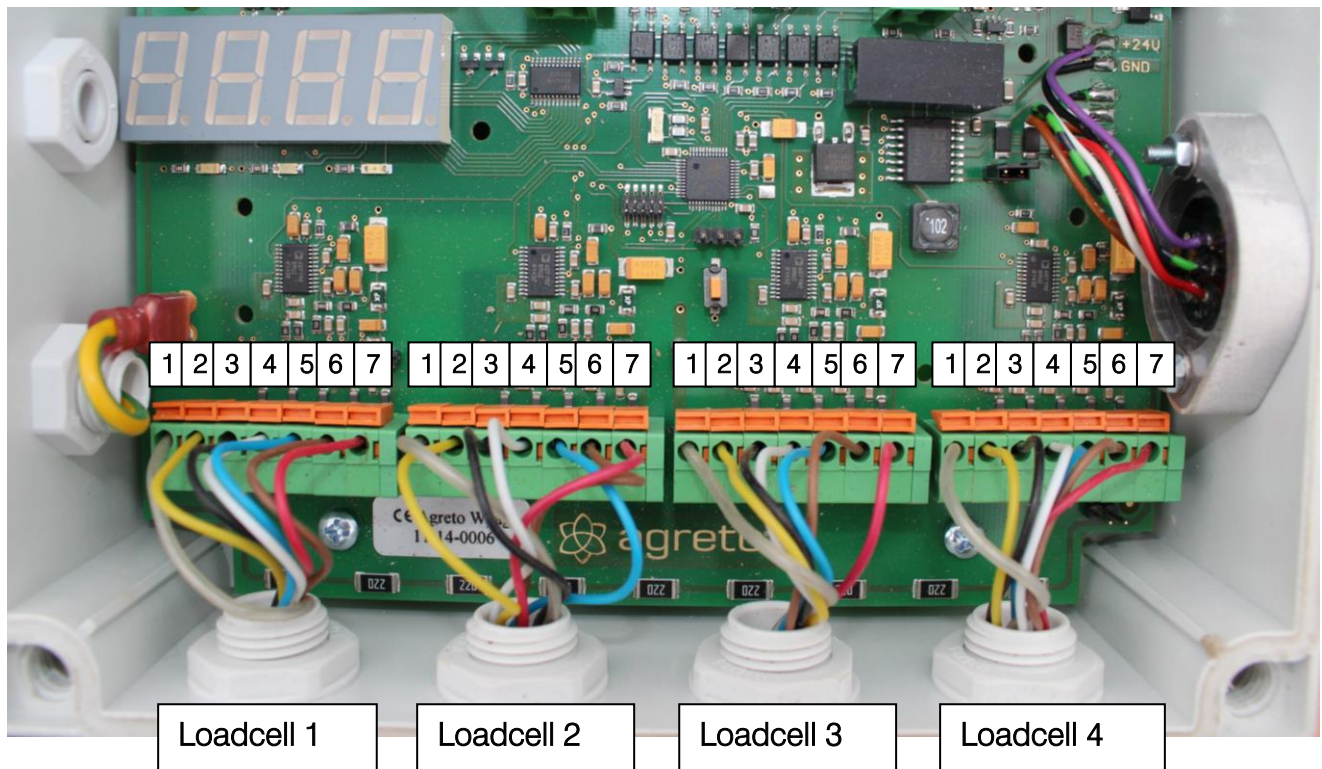

Seven connecting terminals are available for every load cell. Numbering as seen from the signal cable plug:

Position	Wire color	Designation	Description
1	Transparent	SHI	Shielding
2	Yellow	EX -	Power supply -
3	Black	SE -	Sense -
4	White	SI -	Signal -
5	Blue	SI +	Signal +
6	Brown	SE +	Sense +
7	Red	EX +	Power supply +

For load cells with 5-pole connection cables the sense-lines are omitted. In this case every load cell needs 2 bridges between EX+ and SE+, as well as EX- and SE-.

Make sure when connecting the load cells that the scale's power is off.

Make sure that pieces of wire don't end up in the electronics box.

To prevent water from getting into the box, the cable glands must be tightened with suitable tools.

9.6.2 Connecting the grounding

Connect the yellow-green wire on a steel part of the scale.

10 Installing the optional devices

As accessories, a large display, a camera and a remote control are available. Camera and radio remote control require the PC software, they can not be connected to the weighing terminal.

10.1 Installation of the external display

Ideally, the external display should be mounted at the level of the scale with a lateral distance to the scale of approx. 5 to 20 m. So it is clearly visible from both directions already at the start and also after the weighing. If there is a main direction of travel, the display can also be aligned in the direction of the incoming vehicles. The display should still be able to be read from the vehicle after weighing.

In direct sunlight on the display, the readability can be worse. Therefore we recommend in this case to mount a small roof over the display.

The power supply of the external display is carried out with the supplied power cable for 230V. This cable is plugged into a power outlet, which is installed in the area of the display.

The data transfer from the display to the PC or to the weighing terminal takes place with a 3-pole cable. This cable is supplied with mounted plugs in any length up to 100 m. At the weighing terminal the D-Sub connector is plugged in directly. On the PC, the cable is connected to a serial interface or with the supplied USB converter to a USB slot on the PC.

For the connection of 2 external displays - one in each direction of travel - the additionally available Y-cable must be used. This Y-cable is only 2-pin. Automatic recognition or programming of the displays via the Y-cable is not possible.

For the operation of the display on the PC driver installation and settings in the software are necessary, which you can read in the manual.

Pin assignment signal cable 3-pin

Pin on 7-pin round plug	Pin on 9-pin D-Sub plug	Function	Cable color
1	3	Data line PC -> Display (TXD->RXD)	Green
2	2	Data line Display -> PC (RXD->TXD)	Brown
PE	5	GND	White

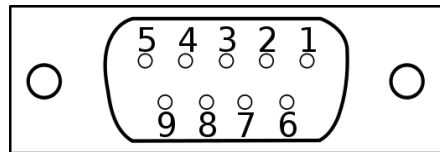
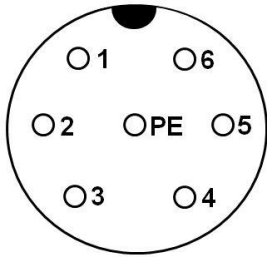

Top view round plug on cable (female)

Top view D-Sub plug on the cable (female)

Pin assignment power supply cable 3-pin

Pin on 4-pin round plug	Function	Cable color
1	L	Red
2	N	Blue
PE	PE	Yellow/Green

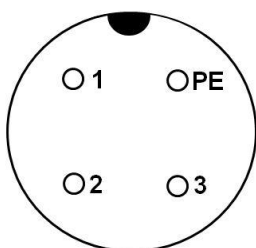

Top view round plug on cable (female)

10.2 Installation of 1 or 2 video cameras

For the identification of a vehicle an upgrade kit is available for image processing. This includes a high-resolution, suitable for night vision, weatherproof video camera including an adapter for the power supply of 220 volts and a USB video converter for connection to the PC. The coaxial cable connection between camera and PC can be up to 100m in length and is manufactured according to your requirements.

Mounting the video camera is best in the range between 5 and 15 m away at a right angle to the weighing platform. Search the optimum position and angle so you can see the vehicles safely and easily. The camera image can be adjusted with the zoom function. The night vision capability of the camera is working up to max. 10m. The smaller the distance, the better the picture at night. Place the coaxial cable to the PC protected from the weather. Connect the coaxial cable with the supplied Chinch adapter to the USB video converter. Supply the power supply of the camera with 230V. Your video camera should now be ready for use.

Driver installation and settings in the software are necessary for the operation of the video camera. You can read that in the manual.

10.3 Installation of the radio remote control

The radio remote control set consists of a housing with the radio receiver and the RS232 interface module for serial communication with the PC, from the radio antenna and from any number of radio remote controls.

Mount the enclosure with the radio receiver and the radio antenna if possible at a location outside where you have visual contact to the incoming vehicles. If no visual contact is possible the position of the antenna should be selected so that the radio signal don't need to be sent through thick walls. The radio antenna has also screw on parts, if you find that the reception radius is too small, you can mount this.

Place the data cable to the PC and connect the cable to either a free serial port with 9-pin D-sub connector or via the included USB converter to. This cable can be delivered with any length specifically for your needs,.

Connect the power supply of the radio control system with 220V. The frequency of the radio control is 433 MHz.

Driver installation and settings in the software are necessary for the operation of the radio remote control. You can read that in the manual.

11 Disposal



Dispose the AGRETO the drive over scales or parts thereof in the definitive shutdown environmentally friendly and sorted (metal scrap to metal, plastic to plastic waste, etc. - Do not dispose as household waste!)

Detailed information can be found in Directive 2002/96/EC

12 Warranty / guarantee AGRETO drive-over-scale

In addition to the legally required warranty, the following warranty conditions apply to the AGRETO three-point scale:

- AGRETO electronics GmbH guarantees proper functioning, and repairs or replaces all parts that exhibit material or manufacturing defects during the warranty period.
- Warranty services are provided by AGRETO electronics GmbH only.
- The decision whether warranty applies, is made exclusively by AGRETO electronics GmbH.
- The warranty period starts when the end user is billed and ends 5 years after the invoice date.
- A requirement for warranty is the presentation of the original invoice and compliance with all the points in this user manual.
- Warranty doesn't apply to wear and tear, nor to damages due to improper use, negligence or accidents.
- In case of a warranty claim transport costs are to be paid by the purchaser.

13 Warranty / guarantee accessories

The legally required warranty applies to the AGRETO drive-over-scale accessories, as well as an eventual guarantee by the supplier of components used.

14 Imprint

All information, specifications and illustrations are as of 2022, subject to technical changes or design changes.

All information in this manual is supplied without liability despite careful preparation. A liability is excluded by the author

Copyright © 2022

AGRETO electronics GmbH
A-8382 Mengersdorf 17

Tel.: +43 3325 20920 0
E-Mail: office@agreto.com
Internet: www.agreto.com